

UP2

Sol[®]
by Sunna Design[®]



USER MANUAL

solarlighting.com



SOL thank you for choosing UP2 Solar Street Light and hope it will give you satisfaction. This manual will familiarize you with the features and operation standards of SOL's UP2 Solar Street Light.

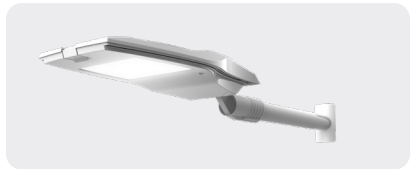
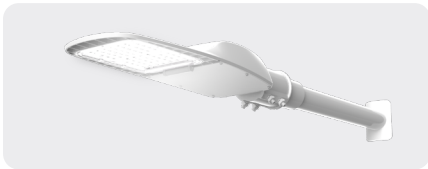

Non-contractual visuals, lanterns may differ depending on chosen options.

Failure to comply with the use, storage, maintenance, installation or placement instructions detailed in this manual could void the applicable user warranty.

1. INSTALLATION AND AFTER SALES SERVICE

Sunna Design, Inc. does not proceed to the installation of products and the purchaser needs to resort to a specialized installer who must comply strictly with the professional standards and with the specifications expressed by the manufacturer in this user manual. As a result, Sunna Design, Inc. does not assume any obligation to provide advice or information regarding the installation of products, the responsibility of which lies solely with the installer. In no case, can the advice or information given by Sunna Design, Inc. when selling products to the buyer be considered as advice or information for the installation of the products.

2. USAGE PRECAUTIONS

Do not open the product without formal written authorization from Sunna Design, Inc., as this will invalidate the warranty. Changes or modifications to Sunna Design, Inc. equipment not expressly approved by Sunna Design, Inc. could void the user's authority to operate the equipment as well as its warranty.

3. STORAGE

Products made by Sunna Design, Inc. include chemical accumulator, storage precautions expressed below must therefore be respected :

- Maximum storage time before use : 1 year
- Maximum storage temperature : 25°C (77°F)



Do not store a product under voltage
(power switch ON)

4. WARRANTY AND RESPONSE

Sunna Design, Inc. guarantee your solar streetlight for six (6) years from date of purchase. For the duration of warranty Sunna Design, Inc. is committed to repair or replace your defective product resulting from a manufacturing or material defect. The warranty applies if and only if the warranty conditions are met. The warranty applies to all components of the product, including the battery pack.



Parts list

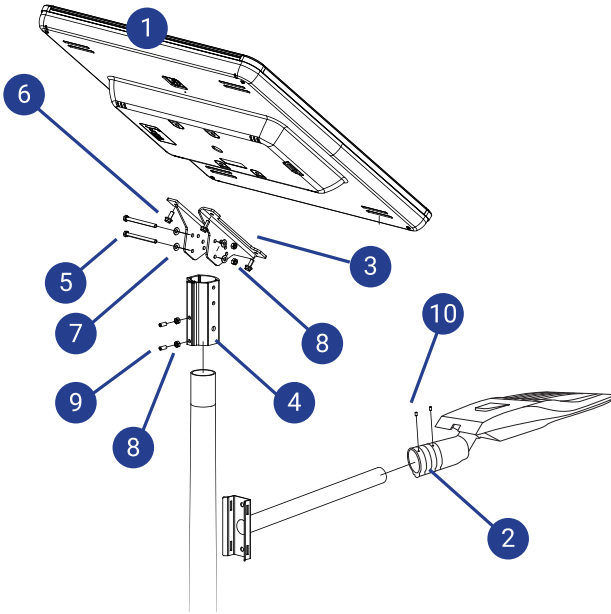

	x1
	x1
	x2
	x1
	x2
	x4
	x4
	x4
	x2
	x2



For safety reasons, please ensure that every element is correctly attached and tightened on the product.

Required tools (non fournis / not included)

	0.1 in. Allen key
	0.15 in. Allen key
	0.5 in. socket wrench



Bracket not included

Checkpoints

• Pole

UP2 is designed to fit on standard poles. Diameter at the top of the pole should be **ø 2.36 in.** Tolerance is **± 0.04**.



CAUTION ! Poles have to be chosen taking into account UP2 weight and site specifications (wind exposition, soil characteristics, etc) in order to have a safe installation. SOL liability won't be engaged in case of pole related incident.

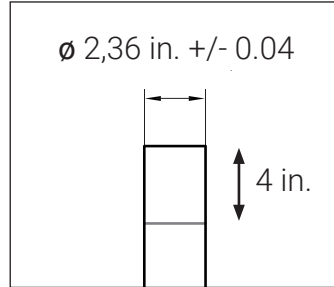

• Shading

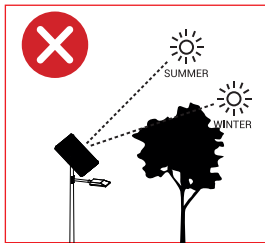
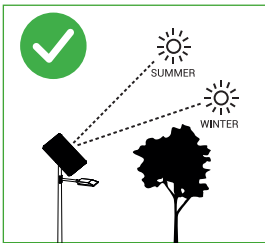

• Light Pollution

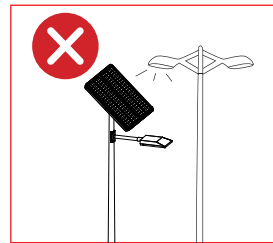

• Angle

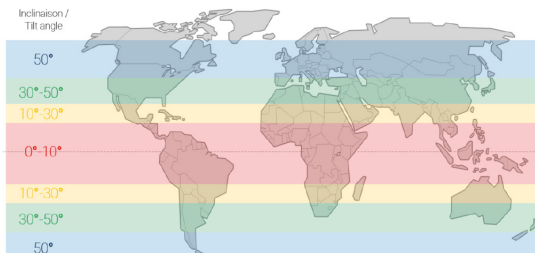

Point solar panels towards the South in the Northern hemisphere

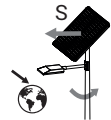

Point solar panels towards the North in the Southern hemisphere

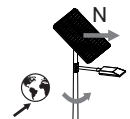

Etapes d'installation / Installation steps

1 Bracket installation

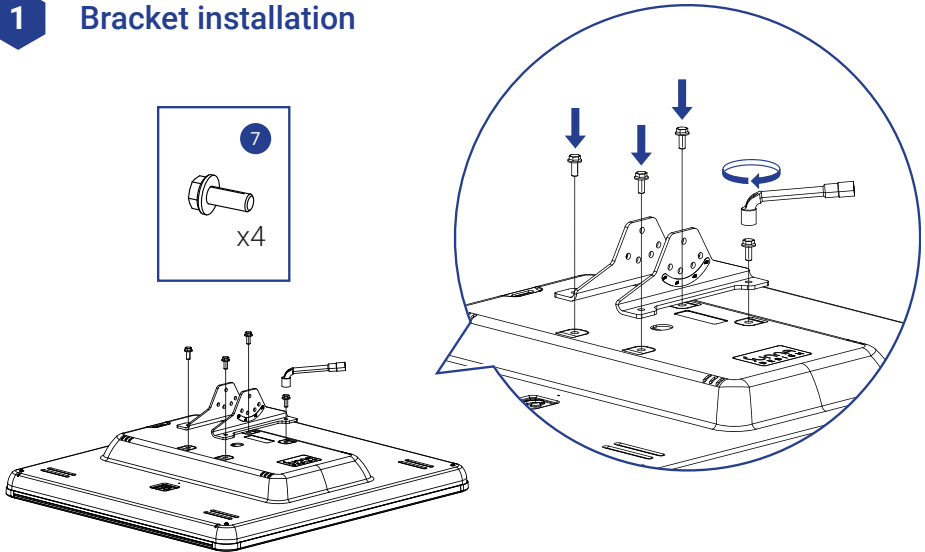

2 Spigot installation and tilt adjustment (cf. p.4)

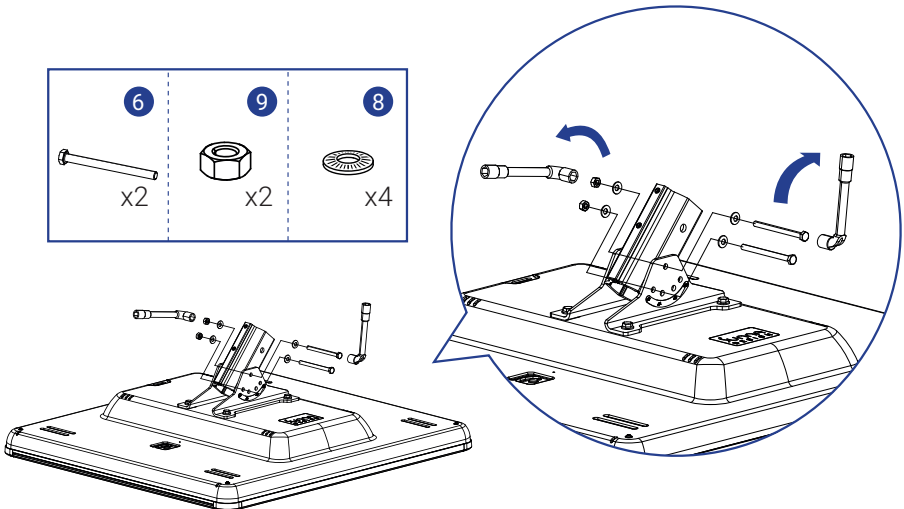

3 Locking on the pole

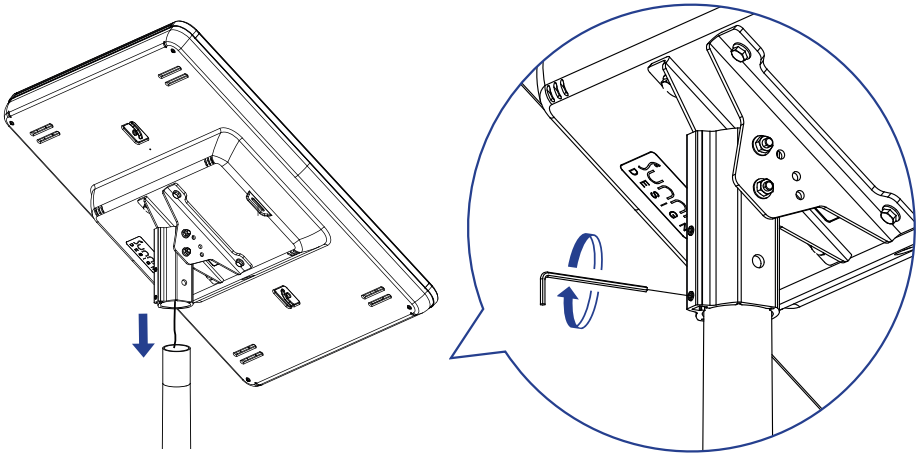

4 Bracket and lantern installation

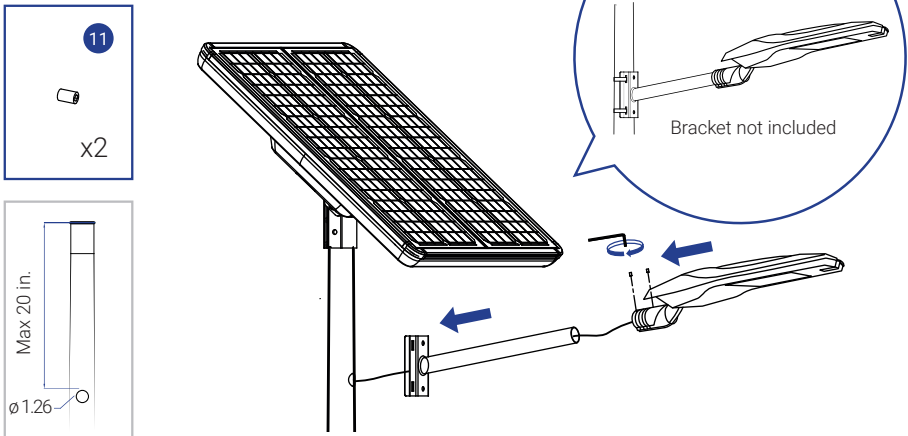

Non-contractual visuals, lanterns may differ depending on chosen options.

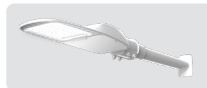

Start-up steps

5 Start-up

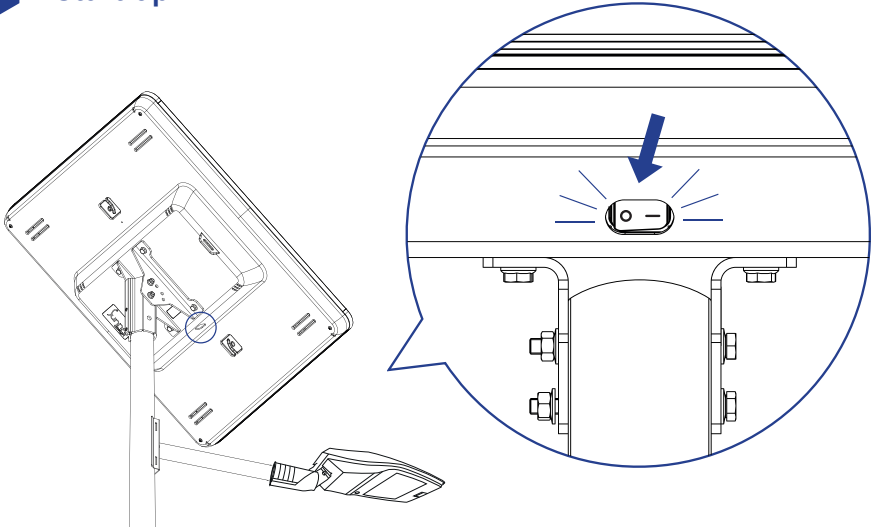

6 Initialization

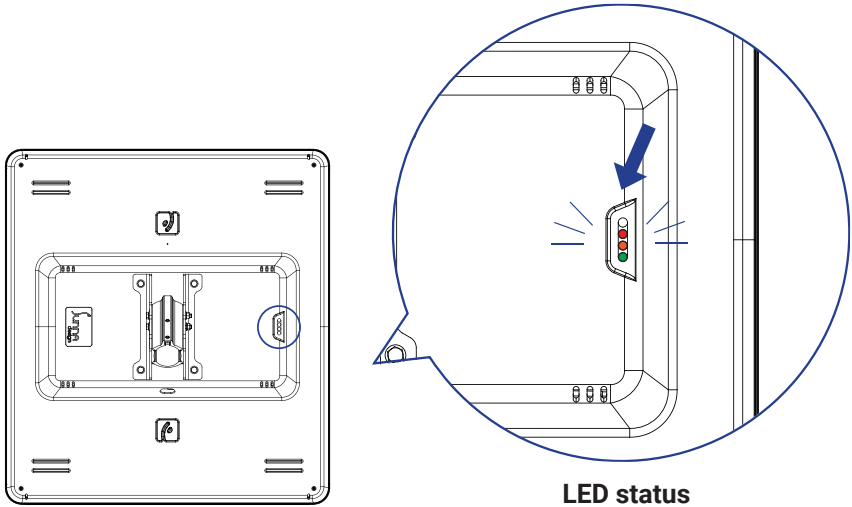

LED status

Calibration

During commissioning, your product will initialize itself.

The aim of this step is to calibrate the product so that you can enjoy its optimal performance.

To that end, the product will fully discharge the battery before initiating a normal charge cycle.

During the first day, the system will not recharge the battery. At nightfall, the LED module will switch on at full power, whatever the battery's charge level (cf. diagram 1).



BLACKOUT RISKS DURING THIS STAGE.

The next day, the system will fully recharge the battery, and, at nightfall, the configured lighting profile will start up. The product is then operational.

NB: This initialization process may last up to 3 days, depending on solar radiation. If not, please contact our customer service.

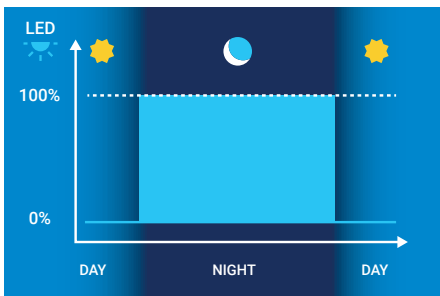

























Diagram 1:
Lighting profile during first night

Description status LED

Status LED : Display & warning function

Green LED	Orange LED	Red LED	Description
 ON	 ON	 ON	Initialization
 Flash	 Flash	 OFF	Day detected
 Flash	 OFF	 OFF	Night detected
 ON	 OFF	 OFF	Bluetooth connected : if connected, no other status displayed
 OFF	 Flash	 Flash	Major alarm
 OFF	 OFF	 Flash	Critical alarm
 OFF	 OFF	 OFF	Product OFF / Battery not connected
 OFF	 Flash	 OFF	Sleeping mode

Maintenance

We recommend occasional visual inspections of solar panels to ensure that they are clean and unobstructed by anything that could prevent the effectiveness of the solar charging, including:

- dirt and dust
- snow
- leaves
- debris
- shade that may have developed after installation due to adjacent plant growth

Motion sensor (optional)

Adding a motion sensor (optional) allows a more powerful lighting during 30s when motion is detected. This solution aims to combine a strong lighting power with a long autonomy.

Settings are set at the factory. The number of detections depends on chosen lighting profile (contact us for further informations) and the detection will stop if the level of energy left in the battery goes below 20%.

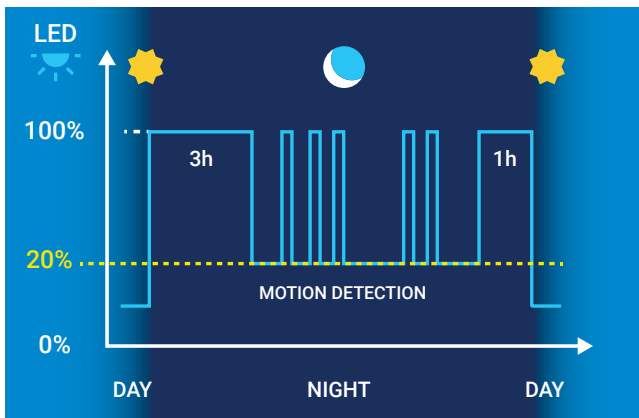

Diagram 2:
Example of lighting profile



Technical characteristics:

Detectable difference in temperature between the target and background is more than 4°C (7,2°F)

Movement speed: 2,6 to 3.2 fps

Detection object = human body
(minimal size is 27,5 in. x 9,8 in.)

Résolution de défauts / Troubleshooting

EVENT	STATUS OF INDICATOR LED			DIAGNOSTIC	CAUSE	SOLUTION
						
LED MODULE DOES NOT TURN ON AT BOOT OR DURING THE NIGHT	OFF	OFF	OFF	Product OFF	Switch not engaged	Switch on the switch (the HMI LED will light up)
	OFF	* FLASH	OFF	Product in sleep mode (Uncharged battery)	Too long storage of the product	Let the product load in the sun
					Bad weather conditions	Product will resume a normal cycle when the weather conditions have become favorable
					Dirty or shady solar panels	Clean the solar panel or move the product if shady
	OFF	* FLASH	OFF	Product temperature is abnormal	Temperature above 80°C (176°F)	Wait for the temperature to return to the operating range
	* FLASH	* FLASH	OFF	Defective night detection	Light pollution on the panel	Move the product if presence of indirect lighting on the panel
OFF	OFF	OFF	Electronic defect	Hardware problem	Intervention required	
LED MODULE STAYS ON DURING THE DAY	* FLASH	OFF	OFF	Day not detected	Extreme weather conditions	Product will resume a normal cycle when the weather conditions are favorable
					Dirty or shady solar panels	Clean the solar panel or move the product if shady
					Brightness is too weak	Wait until the brightness is sufficient for the product to detect the day
THE POWER OF THE LED MODULE IS LOW OR DECREASES AT THE BEGINNING OF THE NIGHT	* FLASH	OFF	OFF	Lighting profile in degraded mode (energy saving)	Adverse weather conditions	The product adapts its energy consumption to work all night (no blackout)

* FLASH : default flashes every 3 seconds; if sleep mode, flashes every minute.



ADDRESS :

Sunna Design, Inc.
990 Biscayne Boulevard, Office 701
Miami, FL 33132 – USA
sales@solarlighting.com
toll free: (800) 959-1329

solarlighting.com